

Hybrid Power Systems Product Guide

Technical specifications and product range for
Australian-made hybrid power solutions.



ABOUT US

HYBRID POWER SYSTEM

Future Power Systems was founded by a team that first worked together in 2017 while delivering one of Victoria's early utility-scale solar farms. After experiencing underperforming hybrid power systems hired for the projects, the team saw an opportunity to build something better.

With backgrounds in electrical engineering and power infrastructure construction, the team designed the FPS20 in 2021 — a portable, foldable hybrid power system designed to meet real-site power demands with greater reliability and durability.

Since then, the FPS range has been refined through extensive real-world testing and continuous technological improvements, with a focus on 100% power availability, high renewable energy contribution, lower fuel use, and the performance customers need in the field.



Proudly Australian-owned and operated.



CONTENTS

About Us	01 - 02
Australian Made	03 - 04
Why Hybrid Power?	05 - 06
System Comparison	07 - 08
FPS Mini	09 - 12
FPS20-10	13 - 14
FPS20-20	15 - 16
FPS20-60	17 - 18
Contact Us	19

AUSTRALIAN MADE

DESIGNED AND BUILT IN AUSTRALIA,
FOR AUSTRALIAN CONDITIONS.

At Future Power Systems, we believe in backing
Australian skills, supporting Australian jobs, and
delivering reliable power solutions that are



From the first sketch to final assembly, our hybrid power systems are designed and built right here in Australia. We understand the unique challenges of Australian worksites – from extreme heat to remote locations.

That's why we build power systems that work as hard as you do.



Why Hybrid Power?

Cleaner temporary power without compromising reliability.

Hybrid generation combines solar, battery storage, and diesel backup in a single intelligent system. It delivers dependable site power while reducing fuel use, maintenance, and emissions.

What is Hybrid Generation?

Hybrid generation refers to a power system that produces electricity from multiple energy sources. In temporary and off-grid power applications, this typically means combining a conventional fuel source, such as diesel or gas, with a renewable source such as solar or wind.

Advances in power system control technology, combined with improved battery storage, have made modern hybrid systems highly efficient, reliable, and commercially practical. Systems such as the FPS range can provide the same power availability as a 24/7 diesel generator while substantially reducing generator runtime, fuel consumption, maintenance requirements, and environmental impact.



How Hybrid Generation Works



1. Solar System

Generates electricity from photovoltaic panels when sunlight is available.



2. Battery System

Stores energy and supplies power when solar output is low.



3. Diesel Generator

Provides backup power on demand when required.



4. Control System

Manages power flow between solar, battery, generator, and site loads.

Solar energy powers the site first. Excess energy charges the batteries. When solar output is low, the batteries supply power. The diesel generator starts only when additional power is required, ensuring reliable performance with lower fuel use and emissions.



FUTURE POWER SYSTEMS

A System for Every Site

	SKID / TRAILER Mini-15 	SKID / TRAILER Mini-20 	SKID / TRAILER Mini-25 	MOST POPULAR CONTAINERISED FPS20-10 	CONTAINERISED FPS20-20 	CONTAINERISED FPS20-60 
OUTPUT TYPE	Single Phase	Single Phase	Single Phase	Single Phase	Single Phase	Three Phase
MAXIMUM CONTINUOUS OUTPUT	14.3 kVA	19.3 kVA	24.3 kVA	22 kVA	30 kVA	117 kVA
SYSTEM PEAK OUTPUT	24.3 kVA	27.3 kVA	36.3 kVA	32.4 kVA	39.4 kVA	137.5 kVA
SOLAR ARRAY	3 kW	6 kW	6 kW	10 kW	10 kW	10 kW
BACKUP GENERATOR OUTPUT	9.3 kVA	9.3 kVA	9.3 kVA	14.4 kVA	14.4 kVA	56.5 kVA
BATTERY CAPACITY (USABLE)	Up to 40 kWh	Up to 40 kWh	Up to 40 kWh	Up to 50 kWh	Up to 50 kWh	Up to 50 kWh
FUEL CAPACITY	100L	100L	100L	200L	200L	200L
WEIGHT	2.1t	2.4t	2.4t	5.50t	5.60t	7.00t
DIMENSIONS (H x W x L)	3.19m x 2.50m x 6.10m	3.19m x 4.08m x 6.10m	3.19m x 4.08m x 6.10m	4.80M x 8.90m x 6.10m	4.80M x 8.90m x 6.10m	4.80M x 8.90m x 6.10m
IDEAL FOR	Smaller temporary power	Small sites and remote works	Higher-load temporary sites	Construction and site compounds	Larger compounds and infrastructure	Industrial and three-phase applications

SUSTAINABLE. RELIABLE.
BUILT FOR AUSTRALIA.

FPS Mini

HYBRID POWER SYSTEMS

The FPS Mini Range is a series of compact, deployable hybrid power systems that combine solar, battery storage, and automatic backup generation.

Designed for rapid deployment and reliable performance in remote and off-grid applications.



TECHNICAL SPECIFICATIONS – FPS MINI

FPS Mini Hybrid Power System



DIMENSIONS

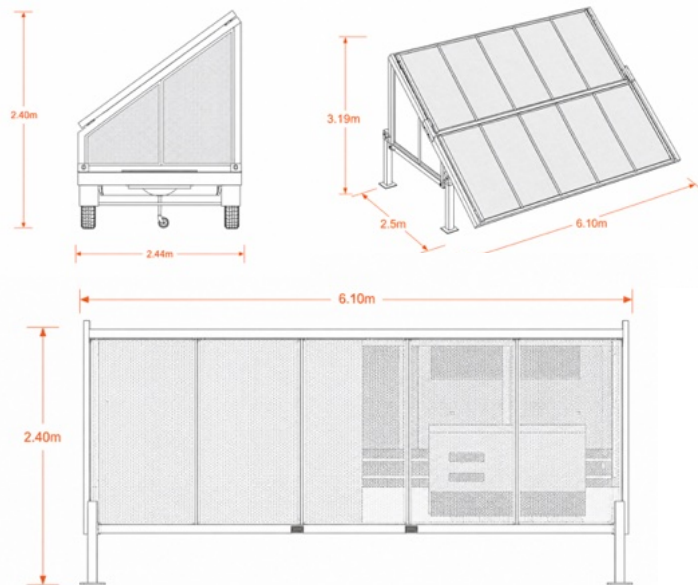

ELECTRICAL SPECIFICATIONS

	Mini-15	Mini-20	Mini-25
Output Type	Single Phase		
Maximum Continuous Output	14.3 kVA	19.3 kVA	24.3 kVA
System Peak Output	24.3 kVA	27.3 kVA	36.3 kVA
Solar Array Size (Roof Mounted)	3075 W	6150 W	6150 W
Expandable Solar (Quick Deploy)	Yes		
Backup Generator Output	9.3 kVA		
Battery Capacity (Usable)	Up to 50 kWh		
Battery Chemistry	LiFePO ₄	LiFePO ₅	LiFePO ₆
Nominal AC Voltage	240V AC		
AC Frequency	50Hz		
Inverter Type	Pure Sine Wave, Transformer Based		

SYSTEM FEATURES



HIGH-EFFICIENCY SOLAR ARRAY
Integrated roof-mounted solar array designed to support daytime renewable



INTEGRATED BATTERY STORAGE
Built-in LiFePO₄ battery storage for quiet operation and reliable stored energy.



AUTOMATIC BACKUP GENERATION
Intelligent backup generation ensures continuous power availability when required.



SKID / TRAILER-MOUNTED DESIGN
Road-towable platform enables efficient relocation between remote, temporary, and mobile worksites.



LOW MAINTENANCE
Robust construction and proven components reduce maintenance demands and lifecycle costs. downtime.



RAPID DEPLOYMENT
Operational onsite within minutes, minimising setup time and project delays.

PHYSICAL SPECIFICATIONS

	Mini-15	Mini-20	Mini-25
Length	6.10m		
Width (Packed)	2.44m		
Height (Packed)	2.40m		
Width (Deployed)	2.5m	4.08m	4.08m
Height (Deployed)	3.19m	3.19m	3.19m
Weight	2.1t	2.4t	2.4t
Fuel Capacity	100L		
Noise Level (Generator Running)	59 dB @ 7m		
Noise Level (Solar/ Battery)	Silent		

OPERATING CONDITIONS

Operating Temperature	-10°C - +50°C
Storage Temperature	-20°C - +60°C
Wind Region (Deployed)	A0 – A5

SUSTAINABLE. RELIABLE.
BUILT FOR AUSTRALIA.

COMPLIANCE AND STANDARDS

The FPS Mini Hybrid Power Systems are designed and manufactured in accordance with relevant Australian Standards applicable to off-grid power generation, battery energy storage systems, photovoltaic installations, and electrical safety.

- ✓ **AS/NZS 3000:2018** Wiring Rules
- ✓ **AS/NZS 5033:2021** Installation and safety requirements for photovoltaic (PV) arrays
- ✓ **AS/NZS 4509.1:2009** Stand-alone power systems – Safety & Installation
- ✓ **AS/NZS 4509.2:2010** Stand-alone power systems – System Design
- ✓ **AS/NZS 1170.2:2021** Structural design actions – Wind actions
- ✓ **AS/NZS 1768:2021** Lightning protection
- ✓ **AS/NZS 3008.1.1:2017** Selection of cables
- ✓ **AS/NZS 5139:2019** Safety of battery systems for use with power conversion equipment

BUILT FOR PERFORMANCE. DESIGNED TO DEPLOY.

IDEAL FOR



Remote Construction Sites



Mining & Exploration



Defence Applications



Emergency Response



Agriculture



Telecommunications



Temporary Events



Infrastructure Projects



MODEL	MINI-15	MINI-20	MINI-25
Maximum Continuous Output	14.3 kVA	19.3 kVA	24.3 kVA
System Peak Output	24.3 kVA	27.3kVA	36.3 kVA
Solar Array (Roof Mounted)	3.1 kW	6.15 kW	6.15 kW
Expandable Solar (Quick Deploy)	Up to 6 kW	Up to 6 kW	Up to 6 kW
Battery Capacity (Usable)	Up to 50 kWh	Up to 50 kWh	Up to 50 kWh
Backup Generator Output	9.3 kVA	9.3 kVA	9.3 kVA
Dimensions	3.19m x 2.50m x 6.10m	3.19m x 4.08m x 6.10m	3.19m x 4.08m x 6.10m



TECHNICAL SPECIFICATIONS – FPS20-10

FPS20-10 Hybrid Power System



DIMENSIONS

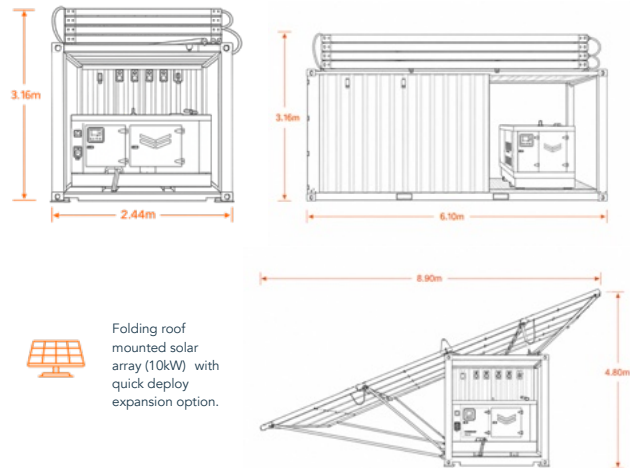







ELECTRICAL SPECIFICATIONS

Output Type	Single Phase
Maximum Continuous Output	22kVA
System Peak Output	32.4kVA
Solar Array Size (Roof Mounted)	10kW
Expandable Solar (Quick Deploy)	Up to 20kW
Backup Generator Output	14.4kVA
Battery Capacity (Usable)	Up to 50kWh
Battery Chemistry	LiFePO₄
Nominal AC Voltage	240V AC
AC Frequency	50Hz
Inverter Type	Pure Sine Wave, Transformer Based

PHYSICAL SPECIFICATIONS

Length	6.10m
Width (Packed)	2.44m
Height (Packed)	3.16m
Width (Deployed)	8.90m
Height (Deployed)	4.80m
Weight	5.50t
Fuel Capacity	200L
Noise Level (Generator Running)	65 dB @ 7m
Noise Level (Solar/ Battery)	Silent

SYSTEM FEATURES

- 
HIGH EFFICIENCY SOLAR ARRAY
 Maximizes renewable energy generation throughout the day.
- 
INTEGRATED BATTERY STORAGE
 Reliable lithium storage for consistent power day and night.
- 
AUTOMATIC BACKUP GENERATION
 Seamless switchover to backup power when required.
- 
MULTI-LAYER REDUNDANCY
 Designed with multiple fail-safes for mission-critical reliability.
- 
LOW MAINTENANCE
 Long service intervals and robust component selection.
- 
RAPID DEPLOYMENT
 Operational onsite in under an hour.

OPERATING CONDITIONS

Operating Temperature	-10°C - +50°C
Storage Temperature	-20°C - +60°C
Wind Region (Deployed)	A0 – A5



TECHNICAL SPECIFICATIONS – FPS20-20

FPS20-20 Hybrid Power System



DIMENSIONS

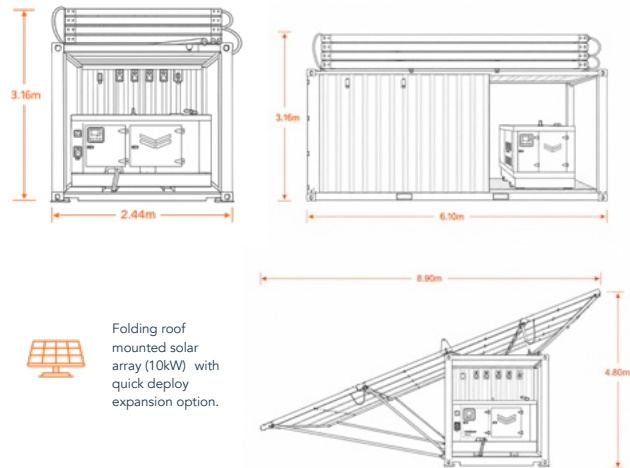

Folding roof mounted solar array (10kW) with quick deploy expansion option.







ELECTRICAL SPECIFICATIONS

Output Type	Single Phase
Maximum Continuous Output	30 kVA
System Peak Output	39.4 kVA
Solar Array Size (Roof Mounted)	10 kW
Expandable Solar (Quick Deploy)	Up to 20 kW
Backup Generator Output	14.4 kVA
Battery Capacity (Usable)	Up to 50 kWh
Battery Chemistry	LiFePO₄
Nominal AC Voltage	240V AC
AC Frequency	50Hz
Inverter Type	Pure Sine Wave, Transformer Based

PHYSICAL SPECIFICATIONS

Length	6.10m
Width (Packed)	2.44m
Height (Packed)	3.16m
Width (Deployed)	8.90m
Height (Deployed)	4.80m
Weight	5.50t
Fuel Capacity	200L
Noise Level (Generator Running)	65 dB @ 7m
Noise Level (Solar/ Battery)	Silent

SYSTEM FEATURES

- 
HIGH EFFICIENCY SOLAR ARRAY
 Maximizes renewable energy generation throughout the day.
- 
INTEGRATED BATTERY STORAGE
 Reliable lithium storage for consistent power day and night.
- 
AUTOMATIC BACKUP GENERATION
 Seamless switchover to backup power when required.
- 
MULTI-LAYER REDUNDANCY
 Designed with multiple fail-safes for mission-critical reliability.
- 
LOW MAINTENANCE
 Long service intervals and robust component selection.
- 
RAPID DEPLOYMENT
 Operational onsite in under an hour.

OPERATING CONDITIONS

Operating Temperature	-10°C - +50°C
Storage Temperature	-20°C - +60°C
Wind Region (Deployed)	A0 – A5

FPS20-60 Hybrid Power System



Length	6.10m
Width (Packed)	2.44m
Height (Packed)	3.16m
Width (Deployed)	8.90m
Height (Deployed)	4.80m

A deployable hybrid power system combining solar, battery storage and automatic backup generation for rapid, reliable off-grid power.

117 kVA Maximum Continuous Output	137.5 kVA System Peak Output	10 kW Roof-Mounted Solar	Up to 20 kW Expandable Solar	Up to 50 kWh Usable Battery	56.5 kVA Backup Generator	Three Phase Output
--	---	---------------------------------------	---	--	--	------------------------------

TECHNICAL SPECIFICATIONS – FPS20-60

FPS20-60 Hybrid Power System



DIMENSIONS

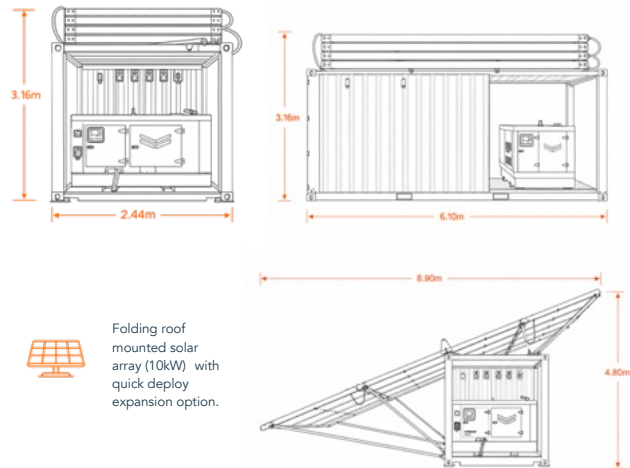







ELECTRICAL SPECIFICATIONS

Output Type	Three Phase
Maximum Continuous Output	117 kVA
System Peak Output	137.5 kVA
Solar Array Size (Roof Mounted)	10 kW
Expandable Solar (Quick Deploy)	Up to 20 kW
Backup Generator Output	56.5 kVA
Battery Capacity (Usable)	Up to 50 kWh
Battery Chemistry	LiFePO₄
Nominal AC Voltage	240V AC
AC Frequency	50Hz
Inverter Type	Pure Sine Wave, Transformer Based

PHYSICAL SPECIFICATIONS

Length	6.10m
Width (Packed)	2.44m
Height (Packed)	3.16m
Width (Deployed)	8.90m
Height (Deployed)	4.80m
Weight	7.0t
Fuel Capacity	200L
Noise Level (Generator Running)	65 dB @ 7m
Noise Level (Solar/ Battery)	Silent

SYSTEM FEATURES

- 
HIGH EFFICIENCY SOLAR ARRAY
 Maximizes renewable energy generation throughout the day.
- 
INTEGRATED BATTERY STORAGE
 Reliable lithium storage for consistent power day and night.
- 
AUTOMATIC BACKUP GENERATION
 Seamless switchover to backup power when required.
- 
MULTI-LAYER REDUNDANCY
 Designed with multiple fail-safes for mission-critical reliability.
- 
LOW MAINTENANCE
 Long service intervals and robust component selection.
- 
RAPID DEPLOYMENT
 Operational onsite in under an hour.

OPERATING CONDITIONS

Operating Temperature	-10°C - +50°C
Storage Temperature	-20°C - +60°C
Wind Region (Deployed)	A0 – A5

CONTACT US

Talk to Our Team

Tell us about your site, timeline and power needs, and our team will help recommend the right hybrid power solution.

Phone

1300 020 800

Email

info@futurepowersystems.com.au

Web

www.futurepowersystems.com.au

Instagram

[@futurepowersystems](https://www.instagram.com/futurepowersystems)

